

Attachment E

**Guidelines for Waste Management in New
Developments – as amended**



Guidelines for Waste Management in New Developments



Recycle these in your yellow lid bin



cityofsydney.nsw.gov.au/waste

CITY OF SYDNEY 

Cover Image: Archibald Avenue, Waterloo / Image: Adam Hollingworth
Above Image: Recycling collection truck / Image: Katherine Griffiths

Contents

01	Introduction	4
	Purpose	4
	Context	4
	Where and when do the guidelines apply?	5
02	How to use the guidelines	6
	Waste and Recycling Management Plan process	8
Sections		
A	General requirements	10
B	Multi-unit residential developments	16
C	Residential single dwellings	19
D	Non-residential developments	20
E	Mixed use developments	24
F	Construction and demolition waste requirements	26
	Abbreviations	28
	Glossary	29
References		
A	Waste generation rates	32
B	Council residential waste and recycling services	34
C	Design requirements for collection vehicle access	36
D	Waste and recycling storage area construction	39
E	Waste chutes, compactors, balers and crushers	41
F	Advanced waste collection systems	43
G	On-site management and treatment of food waste	46

01

Introduction

Purpose

The City of Sydney's *Guidelines for Waste Management in New Developments* (the Guidelines) promote the efficient storage, separation, collection and handling of waste to maximise resource recovery and provide safe and healthy spaces for people to live and work in.

The Guidelines provide the minimum waste management requirements for all development and for completing Waste and Recycling Management Plans for Development Applications (DAs).

All development proposals that will generate demolition, construction and operational waste are required to submit a Waste and Recycling Management Plan. Operational waste is waste generated by occupants of developments as part of typical occupancy and use.

Context

The City of Sydney is committed to environmental leadership. The City's *Sustainable Sydney 2030 – Community Strategic Plan 2017–2021 and Environmental Strategy 2021-2025* set bold targets, including a long-term goal of zero waste to landfill.

The City's *Leave nothing to waste – Managing resources in the City of Sydney area: Waste strategy and action plan 2017–2030* focuses on managing Sydney's resources to 2030 by setting clear targets and recommendations to maximise diversion from landfill. It sets out priority areas that will integrate sustainable resource management within a dynamic and developing urban environment.

One priority area is sustainable design. The City is committed to focusing on sustainable waste management in new developments and these should provide safe and convenient facilities for residents and workers to store recyclables and unwanted waste items for collection and recovery.

The Guidelines are integral in ensuring the City's new buildings maximise resource recovery opportunities through smart, innovative and sustainable design.

Introduction



Kings Cross Return and Earn Machine / Image Ethan Li

Our Targets

By 2030

Targets for our residents

- To divert 90 per cent of waste (with a minimum of 35 per cent as source-separated recycling) from landfill

Targets for our operations

- To divert 90 per cent of waste from City parks, streets, and public places from landfill
- To divert 90 per cent of waste from City-managed properties from landfill
- To divert 90 per cent of waste from construction and demolition, generated and managed by City operations, from landfill

Targets for our businesses

- To divert 90 per cent of waste from operating businesses in the local government area from landfill
- To divert 90 per cent of waste from construction and demolition activities in the local government area from landfill

Where and when do the guidelines apply?

The Guidelines apply to all development within the City of Sydney local government area. The Guidelines were approved by the City of Sydney Council (the Council) in August 2018.

02

How to use the guidelines

The Guidelines should be used by architects, designers, developers, planners, waste consultants, builders, building managers and those involved with the construction, design, management and operation of a building's waste and recycling systems.

The Guidelines also assist with those developments required to prepare a Waste and Recycling Management Plan in accordance with the *Apartment Design Guide*.

The Guidelines are divided into general and individual sections based on development type. Individual sections set out the provisions specific to that type of development for operational waste management. The criteria in each section relevant to the development being proposed should be reviewed and applied as required.

Each section sets out provisions for waste management for development types in relation to:

Space – to allocate sufficient areas within developments for the efficient access, storage and collection of waste and recycling

Access – to ensure waste systems are easy to use and that collection vehicles are able to access buildings to remove waste safely and efficiently

Amenity – to maintain a visually appealing streetscape and minimise the impacts of noise and odour from waste and recycling handling on building occupants, near neighbours and the local area

Safety – to ensure safe practices for storage, handling and collection of waste and recycling

Services – to provide guidance on the Council's expectations for delivering effective waste services including bin handling and collection points, and managing bulky, problem waste and stripout waste

Management – to ensure clarity regarding the roles providing waste management systems for developments and to demarcate service provision

A final section specifies the requirements for managing demolition and construction waste from new and change-of-use developments.

How to use the guidelines



Waste and Recycling / Image: City of Sydney

Reference section

The References section contains technical information that is to be used to inform the design, management and operation of a building's waste and recycling systems. It includes specific waste generation rates, Council's waste services, collection truck information, construction requirements, organics recycling options, and comparative waste storage and collection systems.

Waste generation rates

The waste generation rates for specific premises should be used to calculate the waste and recycling storage space required where there is no existing or previous data on the operational waste data for the development. These calculations and other information as specified can be used in the completion of the Waste and Recycling Management Plans provided in the Appendix.

Waste management local approvals policy

The Guidelines are to be considered in conjunction with the City's [Waste Management Local Approvals Policy](#) which outlines how waste and recycling is to be managed, stored and collected in public places. Waste and Recycling Management Plans are to adhere to this policy, which can be found at www.cityofsydney.nsw.gov.au.

Supporting resources

Applicants may also make reference to the following documents that provide additional guidance for developments to achieve best practice in waste and recycling management. (Note: any future iterations of these documents will supersede older versions).

- *NSW EPA, Better Practice Guide for resource recovery in residential developments, 2019*
- *NSW EPA, Better Practice Guidelines for Waste Management and Recycling in Commercial and Industrial Facilities, 2013*
- *NSW, State Environmental Planning Policy No 65—Design Quality of Residential Flat Development, 2017*

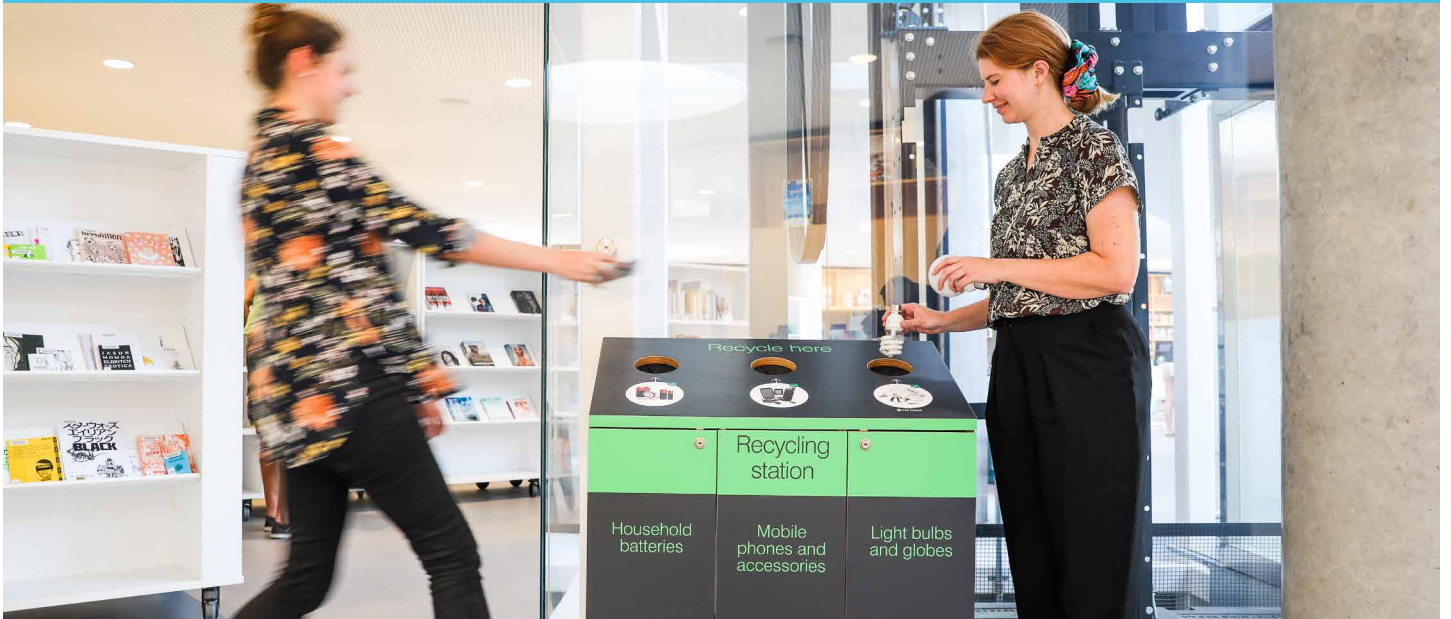

City recycling station in Green Square Library / Image: City of Sydney

Waste and Recycling Management Plan process

A Waste and Recycling Management Plan is to be submitted with all development applications that will generate construction, demolition and operational waste.

Development applications for change-of-use are to address the adjustment of waste management requirements on the basis of these Guidelines to suit the proposed new development type.

Waste and Recycling Management Plan forms can be found at www.cityofsydney.nsw.gov.au/development-guidelines-policies/guidelines-waste-management-new-developments.

Applicants need to complete these forms in accordance with the requirements included in these Guidelines and are to provide the following information in the Waste and Recycling Management Plan:

- 1 *Plans and drawings of the proposed development that show the location and space allocated to the waste management systems and facilities and the nominated waste collection point for the site.*
- 2 *Details of the types and estimated quantities of waste streams.*
- 3 *Identification of the path of access for users and collection vehicles.*
- 4 *Details of ongoing management, storage and collection of waste, including responsibility for cleaning, transfer of bins between storage areas and collection points, implementation and maintenance of signage, and security of storage areas.*

- 5 *Where appropriate to the nature of the development, a summary document for tenants and residents to inform them of the building's waste management arrangements.*
- 6 *Details of the handling of construction, demolition and ongoing waste outputs of the development.*

The completed Waste and Recycling Management Plans, including drawings submitted by the applicant, will be used in the Council assessment of the waste management provisions for the new development.

Please note that inaccurate or incomplete Waste and Recycling Management Plans can delay development approval decisions.

For all residential, non-residential and mixed use developments with a construction value greater than \$5 million, a Waste and Recycling Management Plan is to be prepared by a suitably qualified waste consultant experienced in the appropriate management of waste and recycling generated by new or upgraded developments.

Assessment and approval

The Guidelines are to be used when developing a Waste and Recycling Management Plan throughout the following planning approval stages:

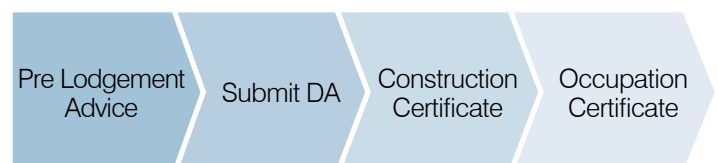

How to use the guidelines



City of Sydney recycling in Town Hall House / Image: Jamie Williams

Pre-lodgement advice

You may contact Council's customer service, planners or waste staff prior to the lodgment of a plan with questions about the requirements contained in these Guidelines. For larger developments, a pre-lodgment meeting to discuss the proposed Waste and Recycling Management Plan is recommended.

Submission of development application

All physical elements of the Waste and Recycling Management Plan is to be detailed on the DA plans for assessment.

The Waste and Recycling Management Plan will form part of the DA application and will be assessed as part of the development assessment process. Key performance criteria for the assessment of Waste and Recycling Management Plans will include:

- Waste storage facilities are designed to minimise impacts on the streetscape, building entry and amenity of residents and tenants
- The recovery of waste is maximised by providing safe, convenient and appropriate space for source separation and recycling
- Waste is separated for maximum recycling

Construction certificate

The development's Waste and Recycling Management Plan is to be submitted before a construction certificate can be issued and is to be consistent with the plans, drawings and DA conditions provided with development consent.

Occupation certificate

For all developments with a residential component, the Council needs to approve the constructed waste management facilities prior to issuing the occupation certificate.

For non-residential developments, the certifying authority is to certify that the constructed waste management facilities conforms to the approved waste management system as set out in the Waste and Recycling Management Plan.

Section A

General requirements

This section sets out the requirements for all development types excluding residential single dwellings. It is to be read in conjunction with the requirements for the specific development types that are set out in the sections that follow.

Waste and recycling storage areas

- 1.1 All waste and recycling is to be wholly located in a dedicated room or storage area.

Storage areas are to provide adequate capacity for storing all the waste and recycling likely to be generated between collection cycles, based on expected waste generation and selected bin types and accommodate likely peak demand for waste storage capacity.

Indicative waste and recycling generation rates for residential and various non-residential sector premises are listed in the *Waste and Recycling Generation Rates* reference section.

- 1.2 Storage areas should reflect the equipment, infrastructure, manoeuvring space and potential future needs of the development.
- 1.3 To allow for safe handling of bins by collection staff and building management, storage areas must provide space for:
 - 10cm between all bins
 - Bins to be stored no more than two deep
 - Aisle space of 1.5m wide
- 1.4 The storage area(s) is to be detailed on DA plans and drawings submitted to Council.

Section A



Household Chemical CleanOut at Alexandra Canal Depot / Image: City of Sydney

- 1.5 More than one storage area, or a temporary waste holding area, may be required in order to provide sufficient storage or to meet criteria for the access and transfer of waste and recycling.
- 1.6 Storage areas are to be located in a position that is convenient for both users and waste collection staff and that promotes source separation and reduces contamination.
- 1.7 The layout of the storage area is to be designed to encourage easy recycling and separation of different waste types by all users.
- 1.8 Storage areas are to be provided within the premises in reasonable proximity to the vehicle entrance, and no lower than one level below street level.
- 1.9 Storage areas are not to be located adjacent to a habitable room.
- 1.10 The design requirements of storage areas are found in the reference section [Waste and Recycling Storage Area construction](#).

Space for waste not suitable for bins

Many businesses and residents need to dispose of items that do not fit within standard collection bins. Allocation of space at the design stage for improved source-separated recycling adds flexibility in buildings to handle these items.

Refurbishment waste and other bulky items are a regular addition to the waste collected within the City and space to store these for collection is required. Mattresses and e-waste are a significant feature of residential waste that can be recycled if collected separately. Items such as batteries, mobile phones and fluorescent lights can be harmful to the environment if not collected separately for recovery.

Many business premises rely on transport packaging for products, such as kegs, pallets, crates and boxes. It is important to provide an opportunity for interim storage of these re-usable items to minimise breakage and loss, to reduce reliance on single-use packaging, and to minimise waste, litter and the use of natural resources.



Waste and recycling bins / Image: City of Sydney

Space for bulky, problem, food organics and compostable material

- 2.1 Separate dedicated space such as a room or screened area (in or attached to the waste and recycling storage area) is to also be provided for the storage and recycling of bulky waste and problem waste for collection (refer to relevant sections for specific size requirements according to development type.)
- 2.2 Dedicated space for organics bins is required within the waste and recycling storage area (refer to *Waste and Recycling Generation Rates* reference section A).
- 2.3 Other compostable material management options can include providing space for:
 - 2.3.1 Composting and worm farming, on an unpaved earth surface or within a bunded and drained area, for developments with external space or in private courtyards that is to be managed by the development.
 - 2.3.2 On-site food organics processing system (refer to reference section *Management and treatment of organics*).

What is bulky and problem waste?

Bulky waste are those recyclable items too large to fit into bins and includes furniture, whitegoods, electronics and mattresses. These items are collected from residential properties as part of the Council's waste and recycling services.

Problem wastes are hazardous items that are not permitted in the general waste bin. This include paints, chemicals, batteries, light bulbs, gas bottles, motor and cooking oils which can be recycled if separately collected and managed.

Waste and recycling collection points

A waste and recycling collection point is the designated position or area where waste or recyclables are loaded onto the collection vehicle.

- 3.1 The collection point is to be level, free of obstructions and with sufficient side, rear and vertical clearance to enable the safe mechanical pick up and set down of bins. An additional 2m unobstructed loading zone is required at the rear of the vehicle for the loading of bins.
- 3.2 The location of the proposed waste and recycling collection point(s) is to be detailed on the DA plans. Collection points for residential and non-residential loads may be shared.
- 3.3 Collection and vehicle access points are not to be located adjacent to a habitable room.

Section A



Recycling in apartment building bin room / Image: City of Sydney

- 3.4** Residential developments are to provide on-site collection of waste, recycling and bulky items by Council vehicles. Waste collection and loading is to be accommodated within new developments in order of preference:
- In the building's basement, no lower than one level below ground
 - At grade within the building in a dedicated collection or loading bay
 - At grade and off-street within a safe vehicular circulation system where, in all cases, vehicles will enter and exit the premises in a forward direction
- 3.5** Residential developments where on-site vehicle access is not possible due to site-specific constraints must provide a waste and recycling storage area or temporary waste holding area that is:
- Sized to accommodate all bins and bulky waste on collection day
 - Directly accessible from the street
 - Within 10m of the nominated collection point
- 3.6** Residential waste from developments with six residential units or less are permitted to have kerbside collection in the following circumstances:
- Where the space required for presentation at kerb does not exceed one-third of the width of the property frontage
 - Where collection activity does not create an obstruction of the pathway or roadway or cause an illegal hazard
- Where the collection point is to be located so as to minimise the impacts from noise and odour during collection
 - Where collection complies with the City's *Waste Management Local Approvals Policy*
- 3.7** All collection of non-residential waste is to be conducted on-site. Consideration will be given to smaller developments where this is not possible.
- 3.8** For non-residential developments, loading docks, ramps and waste collection points must provide access for vehicles as per section 3.11.13 of the Sydney Development Control Plan.
- 3.9** For developments comprising residential uses, loading docks, ramps and waste collection points must provide access for vehicles as per section 3.11.13 of the Sydney Development Control plan , including the 10.6m Council waste collection vehicle detailed in Reference C [Design requirements for collection vehicle access](#).
- 3.10** Please refer to Reference C [Design requirements for collection vehicle access](#) for further information on vehicle access and turning requirements.
- 3.11** The collection point must be located where the waste or recycling collection vehicle(s) can stand safely.
- 3.12** Collection vehicles must enter and exit a site in a forward direction. It is acceptable to use a vehicle turntable to accomplish this. If a vehicle turntable is used, it must have a 30-tonne capacity.



Contractors collecting rubbish bins on Sydney street / Image: City of Sydney

3.13 Collection vehicles must be able to service the development with minimal reversing. If a collection vehicle needs to reverse to complete a collection run, this needs to be detailed in the development's traffic management plan.

3.14 Each collection point is to be easily accessible from the waste and recycling storage areas. The access pathway for transferring bins and bulky waste between storage areas, the waste presentation point and the collection point must be direct, level and free of obstacles, steps or kerbs.

3.15 The maximum manual handling distance for wheeling bins and transferring bulky waste is:

- 10 metres for bins including 120L, 240L, 660L and 1,100L Mobile Garbage Bins (MGBs)
- 3 metres for 1,500L and 2,000L bulk bins and bulky waste

Any proposed variations require further assessment and discussion with relevant Council officers.

3.16 All doorways, corridors and goods lift(s) used to transfer bins and bulky waste must have a minimum width of 1800mm. Consideration will be given to smaller commercial developments where this is not possible.

3.17 The path for wheeling bins between a waste storage area or presentation point and the collection point must not to exceed a grade of 1:14 at any point.

3.18 The proposed method and transfer pathway for bins and bulky waste must comply with the requirements of Work Health and Safety Legislation and relevant Codes of Practice.

3.19 The transfer of bins from the basement via vehicle ramps is not permitted.

Internal waste collection points

The City of Sydney has a population density of over 5,000 persons per square kilometre. To ensure the City's streets are safe, uncluttered and welcoming, it is not feasible for all bins to be presented on the street front for collection.

The Guidelines set out the required clearances for collection vehicle access to buildings, and the options for secure residential and non-residential internal waste and recycling storage rooms. These requirements will allow standard waste and recycling collection to proceed on-site without obstruction or loss of amenity, improving the quality of the City's public spaces.

Forward travel collection

Standard collection vehicles are almost 10 metres long and weigh over 20 tonnes when loaded. The width of these vehicles impedes rear vision. Such vehicles are not suited to manoeuvre requiring major reversing or multiple-point turns. Such driving manoeuvre are a common source of accidents involving large collection vehicles, and can be avoided through improved design of collection point access. These Guidelines set out practical solutions to allow forward movement of a vehicle to collect waste. Forward truck movement improves the safety and efficiency of waste and recycling collection.



Garden organics recycling collection truck / Image: City of Sydney

Management

- 4.1 Responsibility for regular cleaning of waste and recycling storage areas (including bins) and transfer of bins rests with the managing body and is to be detailed in the Waste and Recycling Management Plan.
- 4.2 Standard signage on how to use the waste management system for residential dwellings and what materials are acceptable in the recycling is to be posted in all waste and recycling storage areas, including chute rooms. Signage indicating acceptable materials that are suitable for residential dwellings is available from Council.
- 4.3 All waste and recycling storage areas, chute rooms and access paths are to be kept clean and free of obstructions at all times.
- 4.4 All storage containers for waste and recycling are to be kept in serviceable condition and at the agreed bin numbers at all times. Bin cleaning will be conducted on a regular basis by the managing body.
- 4.5 Waste and recycling storage containers must be stored within the boundary of the development at all times.
- 4.6 'DANGER' warning signs and other appropriate Workplace Health and Safety (WHS) signage are to be prominently displayed at any point of entry to an area of waste chute discharge, or where balers, crushers or compactors operate.
- 4.7 A Domestic Waste Management Charge will be levied by Council on every residential rateable property. Current waste service charges are as listed on Council's Schedule of Fees and Charges at www.cityofsydney.nsw.gov.au.

Bin requirements

- 5.1 All waste and recycling containers are to be clearly and correctly labelled to identify which materials are to be placed into which container. Mobile Garbage Bins (MGBs) will be designed and colour-coded in accordance with the *Australian Standard 4123: Mobile Garbage Containers*.
- 5.2 Waste and recycling containers will have a fixed tight-fitting lid and a smooth, washable internal surface.
- 5.3 All residential waste and recycling awaiting collection is to be stored in the largest suitable Council-approved container (such as a MGB up to 1100L capacity), the details of which are outlined in the *Council Residential Waste and Recycling Services* reference section.
- 5.4 Non-residential waste collection containers are to display contractor information in accordance with the provisions in the Council's *Waste Management Local Approvals Policy*.

Other

- 6.1 No waste incineration devices are permitted.
- 6.2 All waste and recycling systems are to comply with the Building Code of Australia and all relevant Australian Standards.
- 6.3 Heritage conservation considerations may alter some requirements of the Guidelines for the refurbishment of an existing building on agreement with Council.

Section B

Multi-unit residential developments

This section details the waste and recycling requirements for residential developments with shared waste and recycling bins. Applicants should also apply the waste management criteria set out in the *Apartment Design Guide* [note: this section applies to residential flat buildings, boarding houses, student accommodation, co-living housing, serviced apartments and 'build-to-rent' developments].

The City's target is to divert 90 per cent of residential waste from landfill (with a minimum of 35 per cent as source-separated recycling) by 2030

Space within each residence

- 1.1 Space is to be allocated inside each residence for the storage of at least two day's generation of waste and recycling (refer to reference section *Waste and Recycling Generation Rates*).
- 1.2 Space (for a kitchen caddy or similar) should be allocated in the kitchen for the separation of food organics or compostable material.

Waste and recycling storage area

- 2.1 The waste and recycling storage area is to provide space for waste, recycling and organics Mobile Garbage Bins (MGBs), bulky waste, problem waste and textile waste.
- 2.2 A lockable cage, designated screened area or room in or attached to the storage area is to be dedicated for bulky waste and problem waste. The space should be appropriate with the minimum being:
 - 2.2.1 From 6 to 20 units: a minimum of 4 m² total space.
 - 2.2.2 From 21 to 40 units: a minimum size of 4 m² + 1 m² for every 10 additional units above 20 units (or part thereof).
 - 2.2.3 From 41 to 100 units: a minimum size of 8 m² + 1 m² per 20 additional units (or part thereof) above 40 units.

- 2.2.4 Over 101 units: a minimum of 12 m² + 2 m² per 50 additional units above 100 units (or part thereof).
- 2.3 Additional space is required for recycling textile waste such as a clothes bin. The size required is 1 m² per 50 units to a maximum 2 m², with more frequent collections for developments with over 101 units. This space should be in or attached to the storage area.
- 2.4 For boarding houses and co-living housing, designated space for bulky and problem waste must be provided as per requirements in 2.2 and 2.3 with a boarding room or private room in co-living housing being equivalent to a unit.
- 2.5 Waste storage areas are to be easily accessible by the residents of the development, designed to be conveniently used by residents and are to provide access for all residents in accordance with the Council's *Access Policy*.
- 2.6 The maximum walking distance from any entrance of a residential dwelling to the storage area should not exceed 30 metres (lift travel distance not included) and should be located close to lifts and/or stairwells.
- 2.7 Waste storage areas are to be located so as to minimise odour and noise.
- 2.8 The design requirements of the waste storage area are found in the reference section [Waste and Recycling Storage Area construction](#).
- 2.9 If the storage area is in a secure street-level holding area, a Council-approved key system will be required where necessary to allow access by collection staff. Liaison with Council's Cleansing and Waste Services Unit will be needed to install this system prior to an Occupation Certificate being issued. All costs for this are to be borne by the property management.
- 2.10 Any waste and recycling storage area for Boarding Houses shall be located towards the rear of the property, and enclosed to minimise odour or noise disturbance for adjoining properties. If storage is proposed at the front of the site, it shall be screened from view from the streetscape to minimise any visual impact (refer to reference section [Waste and Recycling Storage Area construction](#)).

Chute systems

- 3.1 If a chute system is used, a dual-chute system (two separate chutes, one for waste and one for recycling) is to be constructed for buildings with more than nine storeys.
- 3.2 If a chute system is used in buildings with less than nine storeys, a waste chute is required plus space for recycling bins within chute rooms (at least one 240L MGB per six residences serviced by that chute).
- 3.3 Chutes are to be provided with an opening on each floor, designed to be used by all residents and enclosed within a chute room. Chutes are not to open onto any habitable space and chute openings are to have an effective self-sealing system.
- 3.4 Chutes are to terminate in a waste and recycling storage area and discharge directly into a waste or recycling container in a manner designed to avoid spillage and overflow. Protective skirting between chute and containers is permitted to prevent spillage and minimise dust or spray.
- 3.5 For safety reasons, residents are not to be able to access the area where the chute discharges.
- 3.6 The total maximum travel distance from any residential dwelling entry to a chute system on any given storey is not to exceed 30 metres. Additional chutes may be required for buildings in order not to exceed the maximum travel distance.
- 3.7 Please refer to the reference section [Waste chutes, compactors, balers and crushers](#) for technical requirements.

Chute rooms

- 4.1 A chute room is required on each habitable floor of a development that has a chute system.
- 4.2 The chute room will include (in addition to space for recycling MGBs as required):
- 4.2.1 The chute inlet hopper
 - 4.2.2 Space for spare MGBs (in case of chute failure) allowing for at least one 240L MGB for each six residences serviced by that chute.
 - 4.2.3 Space for large cardboard and/or bulky items to reduce the likelihood of blockages in chutes
- 4.3 Each chute room is to provide access for all persons in accordance with Council's *Access Policy*. Chute rooms are to allow sufficient space to permit easy opening of the chute and chute room door and the storage and manoeuvring of MGBs.
- 4.4 A chute room is not to be located adjacent to a habitable room.
- 4.5 Chute rooms are to display instructions on the use of the waste and/or recycling chute including instructions not to dispose hazardous and bulky material into the chute, and what materials can be recycled using the container(s) provided.

Management

- 5.1 Responsibility for cleaning chute rooms rests with the managing body.

Acoustic considerations

- 6.1 Chutes should be certified in design to be constructed to meet the minimum performance requirements for both airborne and impact noise protection.

Performance requirements are given for both airborne and impact noise protection respectively in terms of a Weighted Sound Reduction Index with Spectrum Adaption Term ($RW + Ctr$) and a Normalised Impact Sound Pressure level with Spectrum Adaption Term ($Ln,W + Cl$) as follows for waste chutes in residential premises.

- 6.2 Any chute, duct or service which carries only residential waste and is to be located in a building to serve, pass through or near a separate habitable area (non-residential or residential) is to be designed and built to be separated by a construction methodology that achieves the following minimum performance requirements:
- 6.2.1 Be of a discontinuous/vibration isolated construction methodology.
 - 6.2.2 Be certified in design by an appropriately qualified acoustic consultant to the satisfaction of a lawful certifying authority to achieve an $RW + Ctr$ of not less than 55 if the adjacent rooms are habitable rooms (includes a kitchen, laundry and hallway) and achieve a $DnT,w + Ctr$ of not less than 50 in verification prior to occupation.
 - 6.2.3 Be certified in design by an appropriately qualified acoustic consultant to the satisfaction of a lawful certifying authority to achieve an $LnT,W + Cl$ of not more than 55 if the adjacent rooms are habitable rooms (includes a kitchen, laundry and hallway) and achieve a $LnT,w + Cl$ in verification of the construction methodology prior to occupation.
- 6.3 Chutes are not to carry waste from non-residential developments unless permitted by development consent and have been appropriately considered by a qualified acoustic consultant.

An appropriately qualified acoustic consultant is a consultant who in the certifying authorities' view possesses the necessary skills to render them eligible at the grade of member in the capacity to practise acoustics with the Australian Acoustical Society or Engineers Australia or works for a firm that would be capable of obtaining membership with the Association of Australian Acoustical Consultants.

Case study

Improved recycling in apartments

More than 75% of the city's residents live in residential apartments. This can often present a number of challenges and opportunities for managing waste and recycling. Challenges can often include: minimal space for waste and recycling bins, uncertainty about what should go in the bins and lack of appropriate signage on or close to bins.

In response to some of these challenges the City has run or supported a number of programs aimed at creating easier access to recycling opportunities for residents and improving recycling outcomes.

The City's Smart Green Apartments program works with a group of 20 apartment buildings each year to reduce greenhouse gas emissions and water consumption and improve waste management. Each apartment building will receive a waste and recycling operational assessment with tailored solutions.

In one of the city's apartment buildings the owners corporation purchased a car space to create a dedicated recycling depot. In addition to the existing recycling and green waste collection services the apartment residents are now able to segregate batteries, light globes, mobile phones, e-waste, clothes and shoes.



Bauhaus Apartments, Pyrmont / Image: Katherine Griffiths

Section C

Residential single dwellings

This section details the waste and recycling requirements for residential dwellings with bins allocated to and managed at each individual dwelling. This includes single-dwelling houses, small-scale villas and townhouses.



Residential worm farming / Image: John Dennis

- 1.1 Space is to be allocated inside each residence for the storage of at least two day's generation of waste and recycling.
- 1.2 Space (for a kitchen caddy or similar) should be allocated in the kitchen for the separation of food organics or compostable material.
- 1.3 Space is to be allocated within each property boundary for storing at least one each of Council-specified waste, recycling, food organics and garden organics bins awaiting collection (see reference section *Council Residential Waste and Recycling Services*). This space is to be detailed on DA plans and drawings.
- 1.4 There is to be an access path with sufficient clearance and of a suitable grade to wheel waste and recycling bins from the bin storage within the property boundary to the collection point. The collection point may be at a Council footpath in proximity to the residence or a nominated collection point within the development agreed to by Council. The access path is not to enter or traverse a dwelling.
- 1.5 The distance from a dwelling to the collection point is not to exceed 30 metres.
- 1.6 A location (within the development boundary) for bulky waste and problem waste collection is to be nominated for multiple villas, townhouses or similar developments.
- 1.7 The location of the proposed collection point is to be detailed on DA plans and drawings.

Section D

Non-residential developments

This section includes special provisions for waste and recycling management in industrial and commercial developments including food and drink premises, small-scale commercial premises, offices, accommodation and entertainment premises (e.g. hotels, restaurants and pubs) and retail outlets (e.g. supermarkets, groceries and convenience stores). This section also applies to community facilities.

The City's target is to divert 90 per cent of waste from operating businesses in the local government area away from landfill by 2030

Space

- 1.1 There is to be space dedicated for storing bulky waste and problem waste for recycling of at least:
 - 1.1.1 2m² for developments under 100m²
 - 1.1.2 4m² for developments between 100m² and 2,000m²
 - 1.1.3 An additional 4m² is required for each retail, accommodation or entertainment development over 2,000 m² and for every 20,000 m² of office space.
- 1.2 Dedicated space (in or attached to the waste and recycling storage area) is to be provided for the storage and recycling of food organics for collection.
- 1.3 A designated space is to be provided on-site in reasonable proximity to retail or commercial premises to store re-usable commercial items such as crates, pallets, kegs, stripout waste and similar items so that storage in a public place is completely avoided.
- 1.4 Kitchens, office tearooms, and service and food preparation areas are to be designed with sufficient, dedicated space to collect and recycle food organics; this is to be indicated on plans.

- 1.5 Secure space is to be allocated for the separate storage of each waste stream including liquid wastes, commercial cleaning products, chemicals, paints, solvents, and motor and cooking oil. These areas for liquid waste storage are to be bunded, and drained to a grease trap, in accordance with legislation and the requirements of State government authorities and agencies.
- 1.6 The use of cardboard balers/compactors and glass crushers for developments with a high generation of cardboard and glass recyclable waste should be considered. The space allocation for storage of recycling in MGBs may be reduced if alternative systems demonstrate the need for less storage space.
- 1.7 Space should be provided for the separate collection of beverage containers suitable for redemption under the NSW Container Deposit Scheme.
- 1.8 Separate dedicated space such as a room or screened area should be provided for the separate interim storage and management of stripout waste for re-use or recycling. Alternatively, this space is not required if the removal of old furniture and material is conducted by a professional stripout service or by the company hired for installing new items. Refer to Better Buildings Partnership, *Stripout Waste Guidelines* at www.betterbuildingspartnership.com.au.

Access

- 2.1 Where collection takes place inside a building, appropriate clearances need to be allowed for the collection vehicle to enter the premises, clear the waste and recycling containers, and exit the premises. Note that some systems require the container to be lifted above the collection vehicle in order to be emptied (such as front-lifted bulk bins or hook lift bins).

Collection

- 3.1 The location of collection points for waste will be located wholly within the boundary of a development and in an area that minimises any noise or odour impacts on the amenity of nearby premises.
- 3.2 Commercial waste collection vehicle specifications should be matched to Council waste collection vehicle specifications as set out in *Design requirements for collection vehicle access*.

Management

- 4.1 Businesses, commercial building tenants and building managers should have written evidence of a valid and current contract (held on-site) with a collector for waste and recycling collection for disposal or processing. If glass crushers will be used, recycling contracts that accept crushed glass would need to be provided.
- 4.2 All businesses should include provisions in their waste contracts that allow for the collection and recycling of high-grade and low-grade office paper, cardboard packaging, paper from secure document destruction, soft plastics, food organics and other recyclable resources from the waste stream.
- 4.3 Contracts with cleaners, building managers and tenants are to clearly outline the waste management and collection system, and are to clearly allocate responsibilities.
- 4.4 Waste management systems should preference on-site weighing of materials.
- 4.5 Where communal composting or worm farming is proposed, it is to be managed and well maintained by the building (preferably by a caretaker, gardener or facilities management) and located in an accessible and visible area to increase awareness and to ensure minimal impacts from any potential odours and that potential run-off is away from site drainage points.
- 4.6 Fittings should be deconstructed or demolished by methods that permit re-use or storage of items such as workstations, and allow for the separation of valuable resources such as metals for recycling.

Requirements for specific non-residential premises

Offices

- 5.1 Provision is to be made on each floor, and in the waste and recycling storage area or any interim holding area, for the separation and storage of all recyclable items (including mixed containers, cardboard, paper and paper products) likely to be produced from the premises.
- 5.2 Provision is to be made in cleaning contracts for this material to be transferred to a central waste and recycling storage area at least once daily. Refer to the *Better Buildings Partnership Best Practice Operational Waste Guidelines* at www.betterbuildingspartnership.com.au for examples of best practice waste management in commercial office.
- 5.3 Storage of paper and cardboard is to be in a dry, vermin-proof area. Paper and cardboard is not to be stored for more than two weeks to prevent breeding of vermin in the stored material.
- 5.4 Rooms or areas designated for printing or photocopying are to provide space for the interim storage of waste paper (in MGBs up to 240 litres) and used toner and/or printer cartridges for recycling.
- 5.5 Each tenancy and common areas should have centrally located bin stations for each stream to remove the need for individual waste bins under desks.
- 5.6 If the development includes more than 20,000 m² of office space, an area for a cardboard baler or compactor is to be provided within or in close proximity to the waste and recycling storage area.

Food retailers and producers

Food retailers and producers can include restaurants, cafes, grocery stores, supermarkets, pubs, clubs and commercial kitchens.

- 5.7 Food premises are to comply with the requirements of AS 4674-2004 Design, construction and fit-out of food premises, including the general waste and recyclable materials requirements. These Guidelines are not intended to alter obligations under that Standard, and in the event of any conflict between these Guidelines and the Australian Standard, the Standard prevails.
- 5.8 The following waste is to be collected daily or stored in a refrigerated waste room until collection (refer to reference section *Waste and Recycling Storage Area construction*):
 - 50 litres of seafood, poultry, and/or meat waste in total each day of operating
 - Waste that contains 20 per cent fish, poultry or meat by weight or volume
- 5.9 Premises preparing food for wholesale distribution or retail should include waste separation systems within or in close proximity to the preparation area to allow for plastic and cardboard waste to be collected and handled separately from food organics. If within the preparation area, all waste is to be removed daily.
- 5.10 Waste oils should be kept separate from food and other wastes.

Retail

- 5.11 For premises with high volumes of cardboard waste, consideration should be made to allocate space for a cardboard compactor, baler, shredder or other volume-reduction equipment.
- 5.12 If the development includes more than 2,000 m² of retail space, an area for a cardboard baler/compactor is to be provided within or in close proximity to the waste and recycling storage area.
- 5.13 Additional space or reduction systems for handling and storing plastic shrink-wrap should be allocated where applicable.

Pubs, clubs and hotels

- 5.14 Clubs and hotels should consider the use of glass crushers to minimise the noise impacts of recycling practices on neighbouring premises. Both glass crushers and cardboard balers/compactors reduce the dedicated space needed to manage recycling, and eliminate the unnecessary collection of bins filled to less than capacity. Use of glass crushers and the allocation of interim storage areas may reduce the space required for recycling storage bins.
- 5.15 If the internal serving area of a club or hotel is larger than 1,000 m², space for a glass crusher is to be allocated.

Accommodation

- 5.16 Hotel accommodation premises with a rise of more than three storeys is to provide on each habitable floor an interim waste storage room or area for separated waste and recycling sufficient for one day's generation of waste and recycling. Such storage room or handling system is to comply with the building's fire management system. Provision is to be made in cleaning contracts for this material to be transferred to a central waste and recycling storage area at least once daily.

Case study

Barangaroo South – Designing a place for zero waste

Lendlease is the developer for Barangaroo South which has 159 residential apartments and approximately 260,000 square metres of commercial space and 65 retailers. It has a target of net zero waste to landfill by 2020 and 80% diversion of waste from landfill from day one of operations.

In the first 2 ½ years of operation, Lendlease has prevented more than 4,000 tonnes of waste from going to landfill (almost 80% diversion). This success is due to many factors:

- The condition that tenants be plastic bag free, use only compostable packaging so that it can be processed with food organics into fertiliser and separate a minimum of five waste streams
- Waste diversion targets are reflected in all tenancy leases and contracts.
- Exceptional data – all waste bins are weighed and monitored. This allows us to identify issues and develop targeted education campaigns and interventions
- Resourcing – the precinct has an onsite waste manager, tenant engagement specialist and dedicated cleaning staff all focused on supporting tenants to achieve the best possible waste diversion rates.



Barangaroo South Precinct / Source: Lendlease

Section E

Mixed use developments

This section details the waste and recycling requirements for developments where residential and non-residential premises occupy the same overall site. Applicants should also apply the relevant criteria set out in the ***Apartment Design Guide***.

The below requirements are to be met along with the residential and non-residential development requirements in Sections A, B and D.

- 1.1 Where a residential development and non-residential development occupy the same site, the waste and recycling handling and storage systems for residential waste and non-residential waste are to be separate and self-contained. Commercial and retail tenants are not to be able to access residential waste and recycling storage area(s) or interim storage containers or chutes used for residential waste and recycling.
- 1.2 Collection points for both residential and non-residential waste and recycling may be shared.
- 1.3 The Waste and Recycling Management Plan is to identify the storage areas, collection points and management systems for both residential and non-residential waste streams.
- 1.4 For non-residential spaces, interim waste storage containers for waste and recycling is to be located on each occupied floor sufficient for one day's generation of waste and recycling. Provision is to be made in cleaning contracts for this material to be transferred to a central waste and recycling storage area at least once daily.

Section E



Ashmore Precinct - Bridge Street, Erskineville / Image: Katherine Griffiths

- 1.5 The collection point is to be designed to accommodate collection vehicles wholly on-site.
- 1.6 Any chute located within the residential component of a mixed use development is not permitted to carry waste generated by non-residential premises.

Waste generation rates

The City has worked closely with businesses to improve its understanding of waste and recycling levels from non-residential developments. The waste and recycling generation rates included in the Guidelines were compiled from actual operations, audits and business surveys. Waste and recycling generation rates for various business premises are important for determining an appropriate storage space for waste collection. The City will continue to work with the commercial sector to update this data to reflect the changes in generation rates over time.

Waste and recycling generation rates for the residential sector are based on residential waste audits of the City's residential collection services. Sufficient storage area means improved recycling levels, and reduced vehicle movements throughout the City to service waste and recycling. These benefits improve the liveability and sustainability of the city.

Waste and recycling generation rates can be found in [Reference A - Waste Generation Rates](#).

Section F

Construction and demolition waste requirements

This section details the requirements for the management of waste from construction and demolition activities.

The City's target is to divert 90 percent of waste from construction and demolition activities away from landfill by 2030

- 1.1 The management of waste from construction and demolition activities is to be minimised by avoidance and reduction practices, re-use on-site and the recycling of materials.
- 1.2 A Waste and Recycling Management Plan detailing these practices is to be completed and included with any new DA (this includes DAs for the change-of-use of a development). The plan should include a target for resource recovery that aims to achieve a minimum 80 per cent recovery rate.
- 1.3 Materials should be sorted on-site for separate recycling collection. If this is not possible, sorting and recycling after the collection of mixed materials from construction and demolition is required. If the ability to recycle a material is adversely affected by being mixed with other waste types, the material is to be stored and collected separately.
- 1.4 On-site or off-site re-use of materials is allowed for unscheduled waste materials not hazardous to human health or safety. Any use of waste materials off-site is subject to the provisions within the *Protection of the Environment Operations Act 1997* and associated regulations.

Section F



Office stripout waste from 580 George Street, Sydney / Image: Katherine Griffiths

- 1.5** The Waste and Recycling Management Plan is to address construction and demolition waste and include:
- 1.5.1** Full disclosure of any asbestos-contaminated material known to be at the site, details of quantities, the licence details of any asbestos removalist, and the designated disposal site licensed to accept asbestos-related waste.
 - 1.5.2** Details regarding how all other waste is to be minimised within a development; and estimations of quantities and types of materials to be re-used or left over for removal from the site.
 - 1.5.3** Details regarding the types of waste and likely quantities of waste to be produced.
 - 1.5.4** Details to re-use or recycle at least 80 per cent of construction and demolition waste, either on-site or diverted for re-use and recycling, with receipts sufficient to demonstrate the target will be achieved.
 - 1.5.5** Details of the off-site recycler's primary destination for materials for multi-unit residential developments over three storeys and all non-residential developments.
 - 1.5.6** A site plan showing storage areas away from public access for re-usable materials and recyclables during demolition and construction, and the vehicle access to these areas.
 - 1.5.7** Nomination of the role/person responsible for ensuring targets are met and the person responsible for retaining waste dockets from facilities.
 - 1.5.8** Designation of appropriately licensed facilities to receive the development's construction and demolition waste.
 - 1.5.9** Confirmation that all waste going to landfill is not hazardous.

Abbreviations

City	the City of Sydney
Council	The Council of the City of Sydney
DA	Development Application
L	litres
m	metres
m ²	square metres
m ³	cubic metres
MGB	Mobile Garbage Bin

Glossary

Term	Meaning
baler	A device that compresses waste into a mould to form bales that may be self-supporting or retained in shape by wire ties and strapping
bulk bin	A moveable container for storing waste and having a capacity of 1.5 m ³ or 2 m ³ . Also known as a skip bin
bulky waste	Solid waste too large to fit into MGBs that typically includes household items, furniture, whitegoods, electronics, cardboard, other packaging and/or mattresses
bunded	To be enclosed by a low wall intended to contain any liquid spillage or inundation from extending beyond an area
chute	A ventilated, essentially vertical pipe for waste disposal, passing from floor to floor of a building with openings as required to connect with hoppers and normally terminating at the lower end within a waste and recycling storage area
chute room	A room located on each floor of a building to enclose waste and/or recycling chutes or the interim storage of recyclable materials
clean-up service	A booked, weekly collection service for large and bulky items such as furniture, whitegoods or garden waste offered by the Council to residents
collection point	The designated position or area where waste or recyclables are loaded onto the collection vehicle
commercial waste	All solid waste generated by a commercial building. Excludes any liquid, clinical, demolition and construction waste
compactor	A machine for compressing waste
compostable material	All vegetable and fruit peelings, coffee grinds, tea bags, egg shells and garden prunings
domestic recycling	Separated recyclable materials (such as cans, glass and plastic bottles, paper and cardboard) generated from households and collected in a marked container for processing
domestic waste	General waste generated from households, commonly termed 'garbage'
dual-chute system	A chute system consisting of two separate chutes, one for waste and one for recycling, each with their own chute opening and exit point
electronic waste or e-waste	Unwanted or broken electronic goods that can be recycled, including TVs, computers and peripherals, electric appliances, mobile phones, VCRs, stereos, photocopiers and fax machines
food organics	All waste from the preparation or consumption of food, including fruit and vegetables, dairy products, coffee grinds, tea bags, bread, rice, pasta, meat, chicken and fish. It does not include grease-trap waste or any packaging. It is often referred to as organic waste
general waste	All non-recyclable, non-hazardous and non-food waste that fits inside the red-lid bin, commonly termed 'garbage'
garden organics	Garden prunings and leaves
incineration device	Any device for the combustion of waste by fire

Guidelines for Waste Management in new developments

Term	Meaning
inlet hopper	A fitting into which waste is placed and from which it passes into a chute or directly into a waste container. It consists of a fixed frame and hood unit (the frame) and a hinged or pivoted combined door and receiving unit
habitable room	A bedroom, living room or kitchen, dining room, study, play room or sun room. This includes rooms in the subject development and neighbouring developments
liquid waste	Non-hazardous liquid waste generated by non-residential premises that is supposed to be connected to a sewer or collected for treatment and disposal by a liquid waste contractor (including grease trap waste)
Lock to lock time	Lock-to-lock time is the time that it takes the driver of the vehicle to turn the steering from full lock in one direction to full lock in the opposite direction in a single continuous movement.
Mobile Garbage Bin (MGB)	A waste container generally constructed of plastic with wheels with a capacity in litres of 120, 240, 660, 1,000, 1,100 or 1,500
multi-unit residential development	Also known as a multi-unit dwelling (MUD), residential flat building or apartment building. It is a residential development with multiple units that have shared waste and recycling bins. It includes low-rise, medium-rise and high-rise developments
non-residential developments	All developments excluding residential developments. Includes industrial, community and commercial developments including food and drink premises, small-scale commercial premises, offices, accommodation and entertainment premises (e.g. hotels, restaurants and pubs) and retail outlets (e.g. supermarkets, groceries and convenience stores)
on-site collection	Collection of all waste and recycling is conducted within the property (in the building's basement, at grade within the building in a dedicated collection bay or at grade and off-street within a safe vehicular circulation system where in all cases vehicles will enter and exit the premises in a forward direction) and not on kerbside
operational waste	Waste generated by occupants of developments as part of typical occupancy and use. This includes all waste streams and materials irrespective of how they are disposed or recovered
problem waste	Waste that cannot easily be managed by regular waste and recycling services and is often hazardous in nature. Problem waste includes paints, chemicals, batteries, light bulbs, gas bottles, and motor and cooking oils. The majority of these items can be recycled if separately collected and managed
refrigerated waste room	A waste room which is refrigerated by a cooling system which maintains the temperature below 5°C
storey	A space within a building that is situated between one floor level and the floor level next above, or if there is no floor above, the ceiling or roof above, but does not include a space that contains only a lift shaft, stairway or meter room, or a mezzanine or attic
stripout waste	Refurbishment waste from commercial buildings
temporary waste holding area	Area where bins and/or bulky waste are transferred to be stored for collection. Bins are required to be transferred back to the bin storage area as soon as possible after collection occurs. This bin transfer is undertaken by a caretaker.
textile waste	Clothing, sheets, linen and other household fabric and textiles
Waste and Recycling Management Plan	A written plan prepared by the applicant(s) setting out the volume and type of waste to be generated during demolition, excavation, construction and ongoing operation associated with a development. It nominates on-site re-use; processes and destinations for recycling and/or disposal of residue wastes; and the operational management of waste and recycling to meet best practice standards. Also known as a 'Waste Management Plan'
Waste and recycling storage area	A dedicated space (including a bin room or bin bay) for the storage of waste, recycling, food and/or garden organics bins, and bulky waste, problem waste and textile waste that is convenient for residents and occupiers to access and use
Waste presentation point	A designated position or area where waste, recyclables or bulky waste are presented for collection by waste service provider. This could be temporary waste holding area or the waste and recycling storage area

References

A	Waste generation rates	32
B	Council residential waste and recycling services	34
C	Design requirements for collection vehicle access	36
D	Waste and recycling storage area construction	39
E	Waste chutes, compactors, balers and crushers	41
F	Advanced waste collection systems	43
G	On-site management and treatment of organics	46

Reference A

Waste generation rates

The waste and recycling generation rates in this section are provided as minimum requirements only. Industry information should be referred to for further details on waste generation rates where available and for specific building developments not covered in this section.

Residential developments	Litres per week			
	waste	recycling	garden organics	food organics
Multi-unit Residential Developments (per unit)*	120	120	120**	8***
Single-dwellings (houses, small-scale villas or townhouse-type developments)	120	120	120	40
Boarding houses and co-living housing with communal facilities (including student accommodation) per occupant	60	60	N/A	8

* This includes serviced apartments and build-to-rent developments.

** Only applies to multi-residential dwellings that generate garden organics (e.g. garden prunings and leaves).

*** This equates to 1 X 120L bin per 30 units, collected twice a week.

Non-residential developments	Expected litres per 100m ² per day*		
	waste	recycling	food organics**
Accommodation and entertainment			
Hotels	20	25	15
Backpackers	30	30	20
Convention/conference / event centres (no accommodation)	50	225	20
Entertainment venues	100	125	30
Restaurant / eating	100	500	100
Pubs / clubs	100	150	40
Commercial offices			
Commercial offices	15	25	5
Retail			
Supermarkets	75	450	25
Specialised grocery	150	300	50
Convenience stores	50	250	10
Bulky goods / department store	40	300	10
General retailing	25	200	5
Community			
General (including libraries)	20	50	5
Child care centres and facilities with kitchens	50	50	15

* Based on data from the Commercial Waste Data Review commissioned by the City of Sydney, document dated 22 Feb 2017. General waste (uncompacted putrescible) and co-mingled recycling waste density factors are applied according to Western Australia Waste Authority figures. Food waste generation is based on a 2016 analysis of the City of Sydney businesses.

** Food waste stream must be separate and cannot be merged with the general waste stream.

Reference B

Council residential waste and recycling services

Mobile garbage bins (MGBs)

Standard measurements

Bin type	120L MGB	240L MGB	660L MGB	1100L MGB
Height	940 mm	1100 mm	1250 mm	1470 mm
Depth	560 mm	735 mm	850 mm	1245 mm
Width	485 mm	585 mm	1370 mm	1370 mm



120 litre MGB



240 litre MGB



660 litre MGB

Standard colours

Stream	Bin body	Bin lid colour
General waste	Dark green	Red
Recycling	Dark green	Yellow
Garden organics	Dark green	Lime green
Food organics	Dark green	Maroon

Collection Services

At the time of publication, Council's residential waste and recycling services are as outlined below. To check the current waste and recycling services, collection zones and waste service charges as listed on Council's current Schedule of Fees and Charges, visit the Council's website at www.cityofsydney.nsw.gov.au.

Please check the Council's website for the latest information on new residential waste and recycling services.

A method for calculating the number of bins required is provided in the reference section *Waste and Recycling Generation Rates* for residential premises. The standard collection service frequency is once a week for waste and recycling. Council will only consider a twice weekly waste collection for approval where it is satisfied that all other options to deliver sufficient storage capacity have been exhausted.

Council does not provide waste and recycling services to non-residential properties.

For multi-unit residential developments

- Waste and recycling collected in 240, 660 or 1,100 litre MGBs
- The use of 1,500 or 2,000 litre bulk bins is allowed only in consultation with Council's Waste Services Unit
- Opt-in Garden organics collected in 240 litre MGBs once per fortnight
- Food organics recycling collected in 120 litre MGBs twice weekly
- Weekly mattress recycling, e-waste recycling and clean-up service by booking only
- Regular e-waste recycling drop-off days and chemical cleanout events for problem waste.

For single dwellings such as houses and terraces:

- Waste collected in 120 or 240 litre MGBs weekly
- Recycling collected in 120 or 240 litre MGBs weekly
- Opt-in Garden organics collected in 120 or 240 litre MGBs once per fortnight
- Food organics recycling collected in 60 litre MGBs weekly
- Weekly mattress recycling, e-waste recycling and clean-up service by booking only
- Regular e-waste recycling drop-off days and chemical cleanout events for problem waste.

Reference C

Design requirements for collection vehicle access

Loading docks, ramps and waste collection points must provide for access for vehicles as per section 3.11.13 of the Sydney Development Control Plan. Waste collection vehicles may be side loading, rear loading or front-end loading. The size of vehicle varies according to the collection service.

Council waste collection vehicle dimensions and design parameters for swept path analysis

Council and its waste contractors use rear-loading, compacting collection vehicles of various capacities up to 24m³ for collecting waste, recycling and bulky waste. The following dimensions are of a typical rear loading collection vehicle and should be used as the design parameters for a swept path analysis in developments comprising residential uses.

Rear loading vehicle	dimensions
Overall length (m)	10.6
Overall width including mirrors (m)	2.9
Track width (m)	2.5
Travel height (m)	3.8
Minimum vertical clearance required (m)	4
Minimum body ground clearance (m)	0.3
Maximum weight (t)	30
Turning circle radius – kerb to kerb (m)	10.5
Lock to lock time (sec)	4
Minimum clearance on both sides of the wheel path (mm)	600
Vehicle turning speed (km/hr)	5-10

Reference C

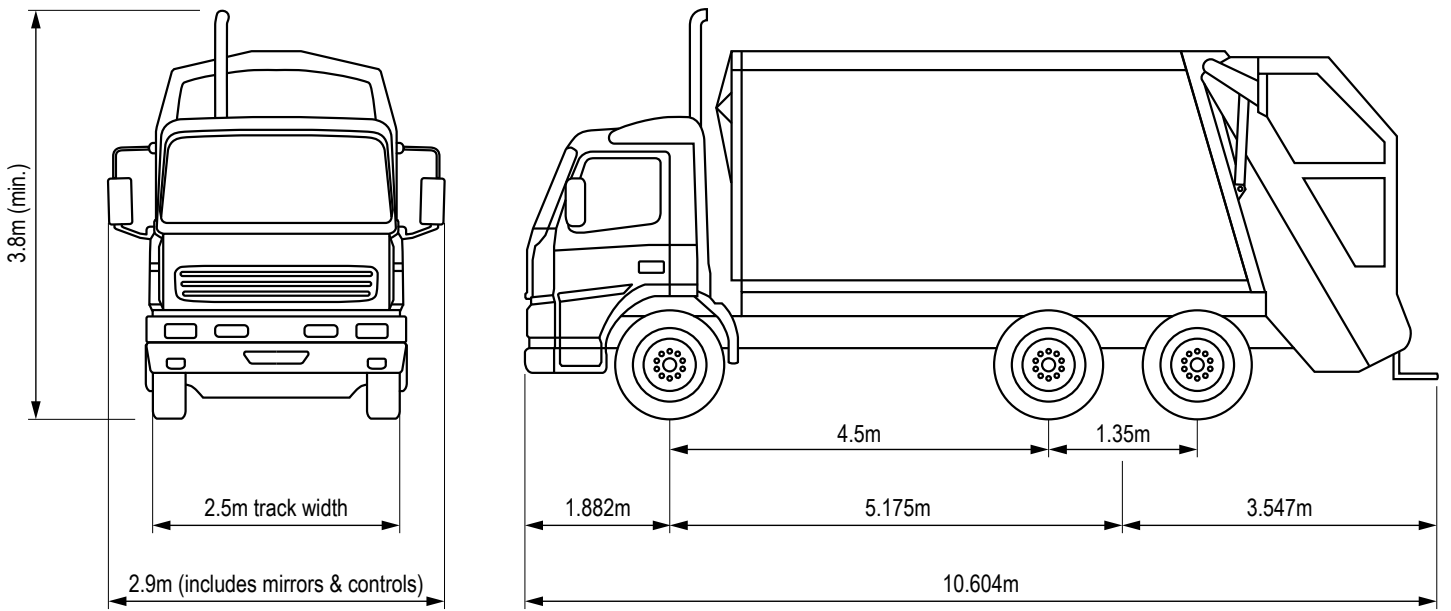

Note: Truck not drawn to scale

10.6m Council collection vehicle (side view)

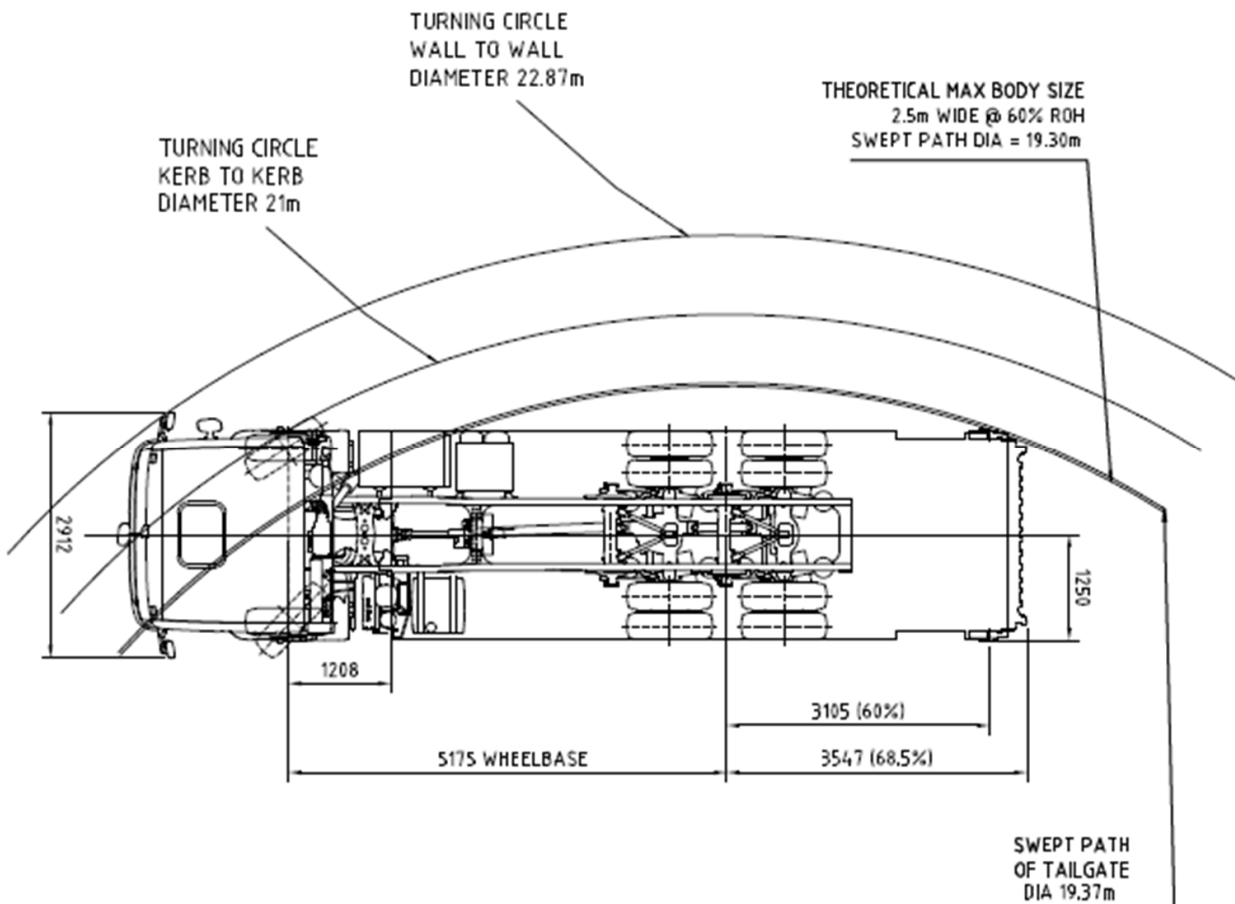

10.6m Council collection vehicle (top view)

Vehicle access and turning requirements for on-site collection in all development types

A swept path analysis should be used to check that the paths of vehicles travelling in the forward direction when negotiating access driveways and circulation roadways, can be accommodated within the proposed location. Swept path analysis should also be used to check the movement out of a loading dock to establish that sufficient width is provided for the vehicle, including manoeuvring clearances. In providing swept path analysis, the following should be provided:

- Details of road geometry (details dimension of the driveway, width of the carriage way, footpath, kerb and gutter, median and on-street parking where applicable)
- Dimension details of the design vehicle
- Turning radius and operating speed
- Lock to lock time. It is recommended that a value between three and six seconds is reasonable for most conventional vehicles. It should come through a vehicle data sheet, however, if not a six seconds should be chosen
- Swept path lines showing the wheel path, vehicle body path and 0.6m clearance path either side of the vehicle body.

The parameter of the design vehicle for swept path analysis should be obtained from the manufacturer specification (with reference) or the parameters in the vehicle dimension table can be used for residential developments.

Best design practice for access and egress from a development calls for a separate entrance and exit to allow the collection vehicle to travel in a forward direction at all times. Where there is a requirement for collection vehicles to turn at a cul-de-sac head within a development, the design is to incorporate either a bowl or 'T' or 'Y'-shaped arrangement.

The design aspects to be taken into account include:

- Placement of waste and recycling bins outside each home, or in a common collection area
- The presence of parked cars on access roads
- Trucks are to only be expected to make a three-point turn to complete a U-turn
- Allowing for collection vehicle overhang and possible interference with bins and road furniture.

Road geometry

The road geometry must be designed in accordance with City of Sydney codes, guides, technical specifications and other applicable design standards.

Structural and material considerations

The proposed vehicle loading area and access route including public driveway must be designed to accommodate a minimum wheel loading of 8 tonnes per axle and 30 tonnes gross total weight in order to accommodate waste and recycling collection vehicles.

Collection within a building or structure

Collection vehicles may enter building basements for the collection of and recycling provided the following requirements are met:

- Maximum grades and rate of change on ramps consistent with the vehicle access requirements in the Sydney Development Control Plan
- Minimum vertical clearance height of the vehicle loading area and access route consistent with the vehicle access requirements in the Sydney Development Control Plan
- The vehicle must be able to enter and leave the site in a forward direction. Space must be provided to allow the typical three point turn of waste collection vehicles or provision made for changing the facing direction of the vehicle.

Reference D

Waste and recycling storage area construction

Construction

- 1.1 The floors, walls and ceilings of waste and recycling storage areas and chute room(s) are to be finished with a rigid, smooth-faced impermeable material capable of being easily cleaned.
- 1.2 The floors of waste and recycling storage areas are to be graded and drained to a Sydney Water approved drainage fitting. The floor is to be provided with a ramp to the doorway where necessary.
- 1.3 A close-fitting and self-closing door or gate operable from within the room is to be fitted to all waste and recycling storage areas.
- 1.4 Doors/gates to the waste and recycling storage rooms are to provide a minimum clearance width of 1800 mm. Consideration will be given to smaller commercial developments where this is not possible.
- 1.5 At least one door or gate to the waste and recycling storage area is to have sufficient dimensions to allow the entry and exit of waste containers of a capacity nominated for the development.
- 1.6 Lightweight roller shutter-type doors or grilles should be considered for access to waste and recycling storage areas, as these do not impact on the available storage space. If these types of doors or grilles are used, the requirement for a close-fitting and self-closing door remains, so that waste collectors can access the waste and recycling storage area other than through the roller door or grille.
- 1.7 The design shall restrict the entry of trespassers, vermin or other animals into the area.
- 1.8 The waste and recycling storage area is to be provided with an adequate supply of water for cleaning purposes with a hose cock. This does not include within chute rooms.
- 1.9 The waste and recycling storage area is to be adequately ventilated by either:
 - 1.9.1 Natural ventilation openings to external air. The dimension of the openings are not to be less than 5 per cent of the bin bay or bin room floor area.
 - 1.9.2 A mechanical exhaust ventilation system in accordance with relevant Australian standards.
- 1.10 Waste and recycling areas are to be provided with artificial light controlled by switches located both outside and inside the storage area.
- 1.11 Any compactors or mechanical devices, if permitted for the mechanical handling and storage of waste and recycling, are to be fitted with safety operating and cut-off systems.
- 1.12 Any facet of the waste and recycling management system that is visible from outside the building is to be in keeping with the dominant design of the remainder of the development.

Refrigerated waste storage

- 2.1 In some instances, Council may require that waste storage be refrigerated. This is likely if large quantities of food waste are generated on-site and waste removal from this site is difficult due to its location or long trading hours. Where a waste room is refrigerated, the temperature is to be maintained at or below 5°C with all refrigeration equipment installed with sufficient space for cleaning.
- 2.2 The floor, walls and ceiling of the refrigerated waste room are to be constructed of a rigid, smooth-faced impermeable material capable of being easily cleaned.
- 2.3 The floor of the refrigerated waste room is to be graded to the doorway.
- 2.4 An adequate supply of hot and cold water is to be provided through a centralised mixing valve with the hose cock located as close as practicable to the doorway.
- 2.5 The refrigerated waste room is to comply with Section G.1 of the Building Code of Australia as well as being provided with artificial light controllable from within the room.
- 2.6 Noise from the use of the refrigeration equipment associated with the waste room is not to give rise to “offensive noise”, as defined under the *Protection of the Environment Operations Act 1997*.

Reference E

Waste chutes, compactors, balers and crushers

Waste chutes

- 1.1 Chutes, service openings and inlet hoppers are to be constructed of metal or other smooth-faced, durable, fire-resistant and impervious material of a non-corrosive nature, capable of being easily cleaned.
- 1.2 Chutes are to be cylindrical in cross-section and the internal diameter is to be a minimum 500 mm and adequate for material being deposited.
- 1.3 Chutes are to be vertical without bends or 'off-sets' and not reduce in diameter over the fall.
- 1.4 Chutes are to be ventilated to ensure that air does not flow from the chute through any service opening.
- 1.5 A cut-off is to be provided at or near the base of the chute to effectively close off the chute while the storage container or compacting device is withdrawn.
- 1.6 Chute rooms are to be provided with an inlet hopper and be in a convenient, well-lit and ventilated positions.
- 1.7 The floor below each charging device and service opening is to be finished with a smooth impervious material with a minimum area of not less than one square metre (1 m²) situated centrally below the inlet hopper.
- 1.8 Inlet hoppers are to be designed to:
 - 1.8.1 Effectively close off the service opening in the chute when the device is opened for loading
 - 1.8.2 Automatically return to the closed position after use
 - 1.8.3 Permit free flow of waste into the chute
 - 1.8.4 Not project into the chute
 - 1.8.5 Permit easy cleaning of the device and connection between the service opening and the chute
 - 1.8.6 Be not less than one metre (1 m) or more than one and one-half metres (1.5 m) above the floor level.
- 1.9 Inlet hoppers are to be capable of delivering the waste to the chute without using force.

Compactors

Compactors are used to compress waste into collection containers to reduce the volume of waste, and are often used in conjunction with chute systems. There are many types of compaction systems. The compaction ratio is typically set at around 2:1.

Compactors must be fitted with optical or visual sensors to provide warning to a nominated caretaker that a bin needs to be replaced. A closed circuit camera may be used, providing it is frequently monitored, such as part of a building security system.

Compactors require regular ongoing maintenance. In particular, systems fed from a chute can be prone to blockages or failure of the 'electronic eye', which can result in waste overflowing or backing up the chute. They also require electricity for operation, which may not be an advantage in buildings seeking to reduce energy demand.

Residential use

Council does not encourage the use of compaction systems for residential general waste, due to issues related to weight, handling and the reduction of bin life. Residential buildings using a waste compaction system that compacts directly into a City of Sydney bin will be responsible for the costs of bin replacements.

Compactors will only be considered by Council as a development condition if other options to reduce waste storage issues, such as optimal bin sizes, have been thoroughly considered and have been proven unable to be used. Compactors are not to be used for recycling material.

Balers

Balers compress bulky materials such as cardboard and plastic film, and tie them into bales so they remain compacted. They are advantageous in situations where large amounts of bulky materials are produced, space is limited and the materials can be compressed so as not to occupy valuable bin capacity.

Balers come in a wide variety of sizes and capacities and have a small footprint. Balers can be customised by size and use requirements. Although some balers operate automatically, someone is normally required to load and operate the baler, which is a disadvantage. The bales can also be large, heavy and difficult to move by hand. Sometimes equipment such as a forklift is required to move them.

Glass bottle crushers

Bottle crushers are designed to break glass into small but recyclable-sized fragments, known as 'cullet'. Most crushers are integrated with a small mobile bin (typically 60 litres) to keep the weight of the cullet within limits for ease of handling. Crushers allow for much larger weights of glass to be stored in smaller volumes, reducing the storage space required for glass recycling by well over 50 per cent.

In addition, the crushers minimise noise associated with handling glass recycling by reducing the need to tip bottles from a bar-sized bin to a larger storage bin, and also from reducing the noise at collection.

Glass bottle crushers are available in different sizes and configurations to suit venues ranging from small bars to larger clubs.

These crushers should be considered in areas of close proximity to residential dwellings to reduce the loss of amenity from recycling noise levels, and where bottle disposal is high and storage areas are limited.

Reference F

Advanced waste collection systems

Developers of precincts or large sites with multiple buildings are encouraged to consider options for advanced waste collection systems. These options are to be discussed and approved by Council before development.

Next-generation advanced waste collection systems which could be considered include automated waste collection systems and alternative bin or container systems.

Automated waste collection systems

Automated waste collection is an integrated network of underground pipes and chute inlets that transport both waste and recycling directly from residential or commercial buildings to a centralised collection point using a vacuum transport. These systems can collect all waste and recycling from an area up to 2.5 kilometres from the central station.

The use of automated waste collection is widespread internationally. Some systems have operated continuously for 50 years. Over 100 cities around the world operate at least one area with automated collection systems, and over one million households are currently connected to an automated waste collection system.

Automated waste is most effectively installed if included at the design stage for new developments. This allows for optimum conveyance pipe layout across the precinct and the incorporation of waste and recycling chutes in multiple buildings integrated with the system.

The key requirements for bins, collection points, access and waste collection for service rooms referred to in these Guidelines may be open to amendment if an automated waste collection system is considered.

Developers interested in installing these systems within a new development should contact Council waste and planning staff at the earliest stage possible.

Benefits

Benefits of automated waste collection include:

- Improved amenity for residents and businesses (reduced odour, noise, spillage and vermin)
- Reduced need for space allocated to waste handling and waste storage in buildings
- Reduced or eliminated need for waste management equipment and bins
- 24/7 access to waste removal (offering reduced commercial waste storage allocation)
- Reduced or eliminated vehicle collection and access at individual buildings, as waste collection would be at a central location rather than scattered throughout a precinct

Requirements

If an automated waste collection system is included in a DA, the following requirements will need to be taken into account:

- The ventilation, air intake and air outlet units shall be located to minimise nuisance to neighbouring premises
- The waste and recycling storage capacity within a building shall be at least one day's waste or recycling output of the building
- Waste and recycling collection points and storage stations shall be accessible to Council collection vehicles, and be located to minimise nuisance to neighbouring premises
- Space for bulky and problem waste storage will still be required
- Adequate measures shall be taken to minimise noise resulting from the operation of the system
- Adequate measures shall be provided to remove dust and smell from the air used for waste conveyance before it is discharged into the atmosphere. The discharge point shall be located away from neighbouring premises



Schematic of automated waste collection system within a development / Source: Envac

Alternative bin systems

Underground bins

Underground bins use hidden capacity by installing large collection containers below ground level. The general user does not see the container but simply a small portion of the container or a small bin above ground. Underground bins are available in a range of sizes including over 5,000 litres. These bins offer the advantage of having a large storage capacity that can be used to effectively manage the waste from many dwellings, while only requiring a small above-ground footprint.

Below-ground storage of waste is an advantage, particularly in summer as the waste is kept cool. The frequency of bin collection may also be reduced significantly, subject to appropriate control of odour and liquids from decay.

Waste collection from underground bin systems can be made by a vehicle that has been modified with a hook-arm or crane. In some systems, the underground bin can be hydraulically lifted for collection from more standard-sized bins.

Both an appropriate location for underground bins and access for collection vehicles are therefore very important due to the servicing method.

Reference F



Hydraulic-underground bins in Darlinghurst, Sydney / Image: Damian Shaw

Shared compaction bins

A number of designs are now available for externally located compaction systems. These systems are typically suited for high-density retail areas. Access is secure, usually by a card identification system. Waste is deposited through an inlet hopper suitable for regular smaller loads arising from retail outlets or some commercial premises. The compactor storage container is typically collected by a hook-lift-type vehicle. When considering these systems, noise impacts and collection access should be taken into account.

Reference G

On-site management and treatment of organics

Composting

Compost bins and piles are a way of processing compostable material and garden organics on-site. This not only reduces the volume of waste but also creates a useful soil enhancer (compost).

Composting can be more versatile than worm farms but needs to be placed directly on the ground so the compostable material are in contact with the earth. Compost bins operate in a very similar way to worm farms but can generally process a wider range of materials including garden organics and citrus.

There are a variety of compost bin arrangements and systems that are commercially available.

The footprint area requirement for a typical compost bin is about 1 square metre.



Example compost bin type
Image: Jamie Williams



Compost bin on residential apartment roof top in Sydney / Image: Richard Payne



Worm farming at Ultimo Community Centre / Image: City of Sydney

Worm Farms

Worm farms can be a cheap and effective method of managing compostable material except for citrus fruit, garlic and onions. Worm farms or vermiculture systems transform compostable material into vermicast (worm compost) and vermi-liquid (liquid extract from the worm farm). These outputs can be used in gardens to promote plant growth. Worm farms can occupy a small footprint and can be located on balconies or in gardens.

Space requirements for a typical worm farm for an average household are (indicative only):

- Height – 300 mm per level
- Width – 600 mm
- Length – 900 mm

There are a number of commercially available worm farms of different designs. They are sold through hardware stores and some specialist suppliers.

On-site food organics systems

The on-site food organics systems summarised here are presented as options only. Further investigation is required by the developer to assess their feasibility. Any on-site food organics system is to be purchased, maintained and managed by the development.

The factors below need to be considered when assessing the viability of separated food waste systems for any development:

- Size of the development and quantities of waste
- Presence of retailers and commercial occupants and quantities and types of waste generated
- Availability of trained staff to manage and operate systems
- Space available for their location
- Ability to separate waste streams or some of their components
- Treatment options required to process any residual food waste
- Commercial collection arrangements needed to collect food waste
- Purchasing of systems and all ongoing maintenance and cleaning is the responsibility of the development.

Developers interested in installing the following systems within a new development should contact Council waste and planning officers at the earliest stage possible.

Food macerators

These systems pulp food and store it in a tank at the source. They are commonly found in commercial premises and have the potential for use in residential buildings. When the tank is full, the contents are collected by truck and taken to a treatment facility, such as an anaerobic digester.

Decomposers and dehydraters

These systems are scalable and rapidly decompose or dehydrate food waste by heating and agitating the waste over 24 hours. This can occur with or without the addition of bacterial starter cultures. They reduce the volume of food waste by removing most of the water it holds. They do not produce compost but only dehydrate waste. Generally these containers need a sewer connection to dispose of the waste water and/or a filter for the vapours vented to the air. This may require additional Council approval. The outputs from these containers can be sent to a lawful facility such as a commercial composting facility.

The organic matter captured from these containers cannot be directly applied to land without an environment protection licence or a Resource Recovery Order and Resource Recovery Exemption.

Anaerobic digester

On-site anaerobic digesters are systems that use bacteria to break down food waste in an oxygen-free environment. The resulting biogas that is produced during this process can be used as an on-site energy source.

Although anaerobic digester technology isn't new, an on-site closed loop system to treat a building's food waste is a relatively new development in Australia. Some trials are currently underway across the country and viable systems will become more commonplace in the future.

Food waste disposal units

A kitchen food waste disposal (FWD) unit (also known as an in-sink macerator) is a mechanical appliance that is installed under the kitchen sink and connects to the drain. Householders feed food waste into the unit which grinds it and, diluted with tap water, sends it into the sewer system or into a septic tank.

Council generally does not support the use of this technology, due to the increased load it puts on the sewage system and because of its relatively low resource recovery rates. However, some FWD systems which may be considered have on-site collection and containment which do not need attachment to the sewer system but instead require periodic pumping.

Sydney Water does not generally encourage the use of FWDs in residential households due to the issues below. However, it is recommended that developers contact Sydney Water if considering FWDs to seek the latest advice.

The disadvantages of FWD units include:

- Increase in wastewater services costs to customers due to additional organic load on the sewer system
- Increased disposal of fats and oils in sewers, which can harm the environment around sewerage outlets and contribute to pipe blockages
- Increased water use for flushing the food waste
- Increased energy use to run the appliance

Recycling

可回收垃圾



Recycling

可回收垃圾



CITY OF SYDNEY

